

High Speed Stepper Drive Label Applicator



 **auto labe**

MODEL 160

Toll Free 800-634-5376

Packaging - Processing
Bid on Equipment

1-847-683-7720

www.bid-on-equipment.com

MODEL 160

The Model 160 stepper drive label applicator is designed for high-speed applications that need exceptional placement accuracy. The remote keypad control system and self teach operation allow for easy set up. The stripper plate assembly is fully adjustable and can be extended away from the applicator for precise label placement close to the product. The one-piece main plate construction and larger bearing shafts are designed to give years of maintenance free operation. Fast and accurate labeling of top, bottom or sides of products.

Features:

- High speed stepper motor driven.
- LCD operator interface for easy menu selection.
- Photo electric label sensor for greater accuracy.
- Label roll capacity up to 16 inch outer diameter.
- Self teaching applicator for easy label size changeover.
- Left & Right hand models.
- Exceptional label placement accuracy.

Specifications:

Speed:

Up to 3000 inches per minute.

Web Width:

Up to 6.5 inches.

Electric Requirements:

110 VAC 60Hz/5 AMP
220 VAC 50 Hz

Equipment Weight:

70 lbs/31.75kg (approximate)
Applicator only

Equipment Dimensions:

24"W x 37"L x 39"H
Applicator only

Options:

- Adjustable heavy duty stand.
- Photo electric product sensor.
- Hot stamp imprinting.
- Conveyor systems.
- Encoder interface.
- Spare parts kits.

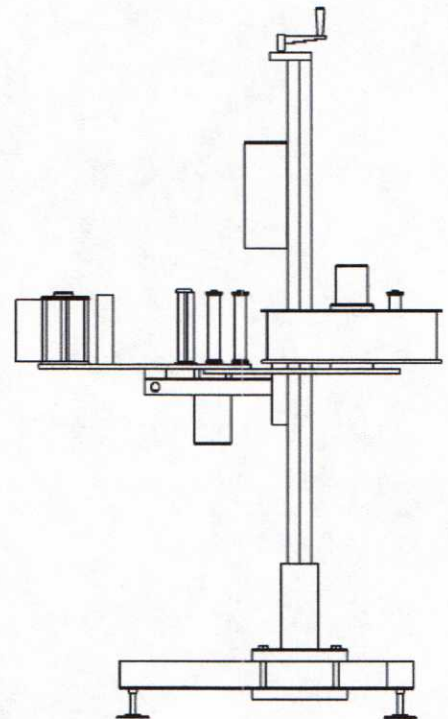
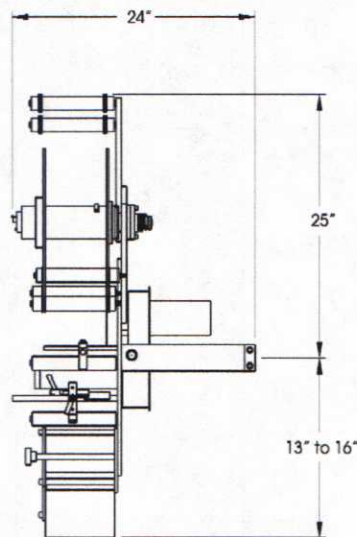
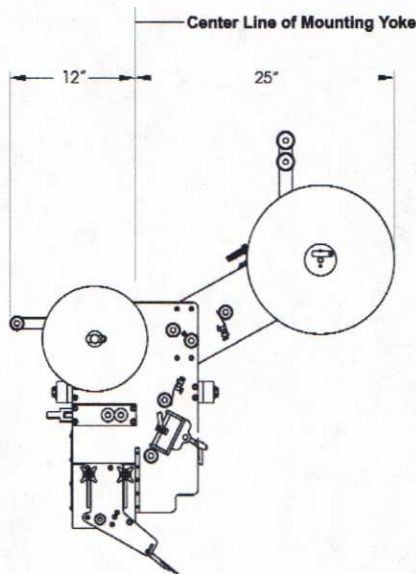

Over 35 years of commitment to quality and innovation
in the Pressure Sensitive Labeling Industry

 **auto labe**

DIVISION OF BOOTH MANUFACTURING COMPANY

3101 Industrial Avenue Two, Fort Pierce, Florida 34946

Toll Free 800-634-5376 • 772-465-4441 • FAX 772-465-5177

MEMBER



Packaging - Processing
Bid on Equipment

1-847-683-7720

www.bid-on-equipment.com